



Guotai Hengxing



Contact Information

Phone Number: 139-1078-8083 / 153-3023-6162

Address: Building 1, Big Data Intelligent
Industrial Park, Liye Road, Huilongguan
Town, Changping District, Beijing

Contact: Mr. Liu

Email: liuchao@gthx-bj.com

Guotai Hengxing (Beijing) Co., Ltd.

Choose Guotai for reliable quality.



Company Profile



1. Guotai Hengxing (Beijing) Company was established in 2010 and is headquartered in Beijing. The company mainly engages in and cooperates with domestic and international chip brands. Domestic brands include Jintek, National Technology, Zhi Xin Wei, Run Stone, Core Connectivity, Unigroup Guoxin, CASIC Micro, Crystal Guide Micro, Guanyu, Yuan Te, Qingzhou Longsheng, among others. The company also represents internationally renowned brands such as ADI, Infineon, Micron, STMicroelectronics, NXP, Xilinx, Broadcom, Atmel, and others. The chip industry involves a wide range of sectors, and the current sales revenue exceeds several billion RMB.
2. Guotai Hengxing (Beijing) Technology Co., Ltd. has branches in Hong Kong, Shanghai, and Shenzhen, ensuring the direct delivery of goods worldwide. The company has an experienced sales and technical service team. Since its establishment, it has developed strong cooperative relationships with several renowned national and international universities, high-tech research institutes, and high-tech companies, earning widespread praise from industry professionals.
3. The company has established the "Precision Online" comprehensive product service platform, the first of its kind in China, providing customers with one-stop services.
4. The company operates three major warehousing centers in Beijing, Shenzhen, and Hong Kong, directly connected to major electronics markets nationwide and worldwide to meet all customer chip needs for research and production.
5. Guotai Hengxing has an SMT factory in Hai'an, Nantong, and molding factory in Tianjin, offering customers precise and convenient one-stop product services.

Head Office: Guotai Hengxing(Beijing) Technology Co., Ltd.

Huizhi Technology Co., Ltd.

Branch: Shenzhen Tianlong

(Beijing) Technology Co., Ltd.

Branch: Huaxia Hengxing

Hongkuo Technology Co., Ltd.

Branch: Shanghai Shengda



Specialized in electronic components sales

SMT, and injection molding



Number of employees

200+



Annual product sales

Over 100 million



Company Culture and Vision



Core Mission

We believe that the total value of a company is derived from human capital, financial capital, labor (including knowledge), and strategic ideas (including risk management). By leveraging advanced concepts and effective risk management, and by continuously investing in knowledge and research, we transform financial capital into products, thereby realizing the company's full value.



Team Value

Guotai Hengxing fosters team building through strategic equity arrangements, ensuring effective company control and sustainable growth. The company implements an employee stock ownership plan and options reward system, aligning employees with the corporate culture to create a unified community. This approach promotes responsible and talented employees to key positions.

Guotai Hengxing emphasizes efficiency, fairness, and sustainable development, balancing compensation based on labor and capital.



Customer Value

Guotai Hengxing is expanding its sales network and introducing complementary agency lines to enhance its competitive edge. The company is committed to mergers and acquisitions in the supply chain, strengthening its technical design and service capabilities in electronic components. By focusing on partnerships, Guotai Hengxing offers comprehensive product solutions to manufacturers, significantly reducing the development and launch time for new products.



Social Value

Guotai Hengxing is committed to contributing to the nation through industry. All members of Guotai Hengxing embody this principle through their actions, integrating it into their daily work and making it the spiritual foundation for the company's sustainable



Product Portfolio



Services



For urgent and scarce parts, choose Guotai for worry-free quality purchases.



PPV SAVING Service

Guotai Hengxing uses its global supply network and unique management system to find the lowest-priced components worldwide in real time. We provide market insights for CPUs, memory, integrated circuits, and connectors, offering stockpiling services for scarce items before shortages and price hikes. With over 16 years of continuous "24/7" global service, we ensure fast and secure delivery of quality products.



BOM (Bill of Materials) Support Service

We integrate different customers' bills of materials (BOMs) and bundle purchases to achieve lower unit prices. Our global "24/7" service allows us to handle your needs more flexibly and quickly, saving procurement time. With swift and secure logistics services, we help reduce your logistics costs. Our professional sales and procurement team provides extensive purchasing advice and comprehensive BOM integration. Additionally, our financial support ensures that you don't face difficulties during payment.



Inventory Management Service

Our global customer platform quickly finds the most suitable buyers for your obsolete inventory. With a powerful database management system, we analyze potential market demand for each item of obsolete stock. Our fast and secure logistics platform ensures rapid inventory transfer between domestic and international warehouses. The latest real-time information platform optimizes the recovery value of your obsolete inventory.





品质保障

"Quality First" is Guotai Hengxing's guiding principle. As a preferred supplier for renowned global companies, stringent quality control is key to our success. We are committed to a "zero-defect" quality management system, covering everything from supply chain management and transaction monitoring to supplier grading and quality inspection processes.

As pioneers and leaders in quality management, our philosophy is "Proactive Action." Our layered quality management strategy ensures our strong position in the electronic component supply chain. Since adopting the ISO 9001:2001 management system in 2013, we have been recognized as a "qualified supplier" by many leading industry players. In 2005, Guotai Hengxing became a registered member of the International Electronic Distributors Association (ERA). Quality management is embedded in every aspect of our operations, and we continuously innovate and enhance our quality management system to achieve our "zero-defect" goal.

Quality Management System

1. Supplier Auditing
2. Quality Inspection
3. Third-Party Testing
4. Storage/Packaging
5. Transport Standards
6. Quality Control Database
7. RMA Process

Third-Party Inspection Partner

1. Baima Laboratory
2. Foxconn South China Testing Center
3. China Electronic Components Center Laboratory
4. Fifth Institute of Electronics, Ministry of Industry and Information Technology



主要客户

Our clients span various sectors, including consumer electronics, computers and peripherals, communication equipment, industrial control, security devices, power supplies, medical equipment, and automotive electronics, across cities worldwide. We serve over 3,000 renowned international and domestic manufacturers, such as Great Wall Motors, BYD, Foton Motors, NIO, Dongfeng Motors, Nanjing Bosch, Kingway, Huayang General, Desay SV, Shanghai Sanqi, Shanghai Longqi, Xinda Hao, Henan XJ, NARI Group, Sunrise, Leyan, Huaxiang, Shenzhou Kun Tai, Suofang Technology, Great Wall Computer, Yangtze Computing, Lenovo Kaitian, Hisense, GoerTek, Shijiazhuang Tonghe, Shijiazhuang Korin, Meiya Optoelectronics, Sunshine Power, iFlytek, Inspur Communication Technology, Inspur Information, H3C, and the 52nd and 23rd Research Institutes of the Weaponry Group.

Jintek Products

Consumer Storage		产品形态
应用领域	Laptop, Desktop-Computer, Smartphone, Wearable Device, Set-Top Box, In-Vehicle System	内存, 固态硬盘, 嵌入式产品
Industrial and Storage		产品形态
应用领域	Computer Network, Monitoring System, Medical Device, Automation Equipment, Industrial Computer, POS Machine	内存, 固态硬盘
Enterprise Storage		产品形态
应用领域	服务器, 网络机, 云计算, 通讯机, 网关, 工作站	内存, 固态硬盘



Runstone Product Line

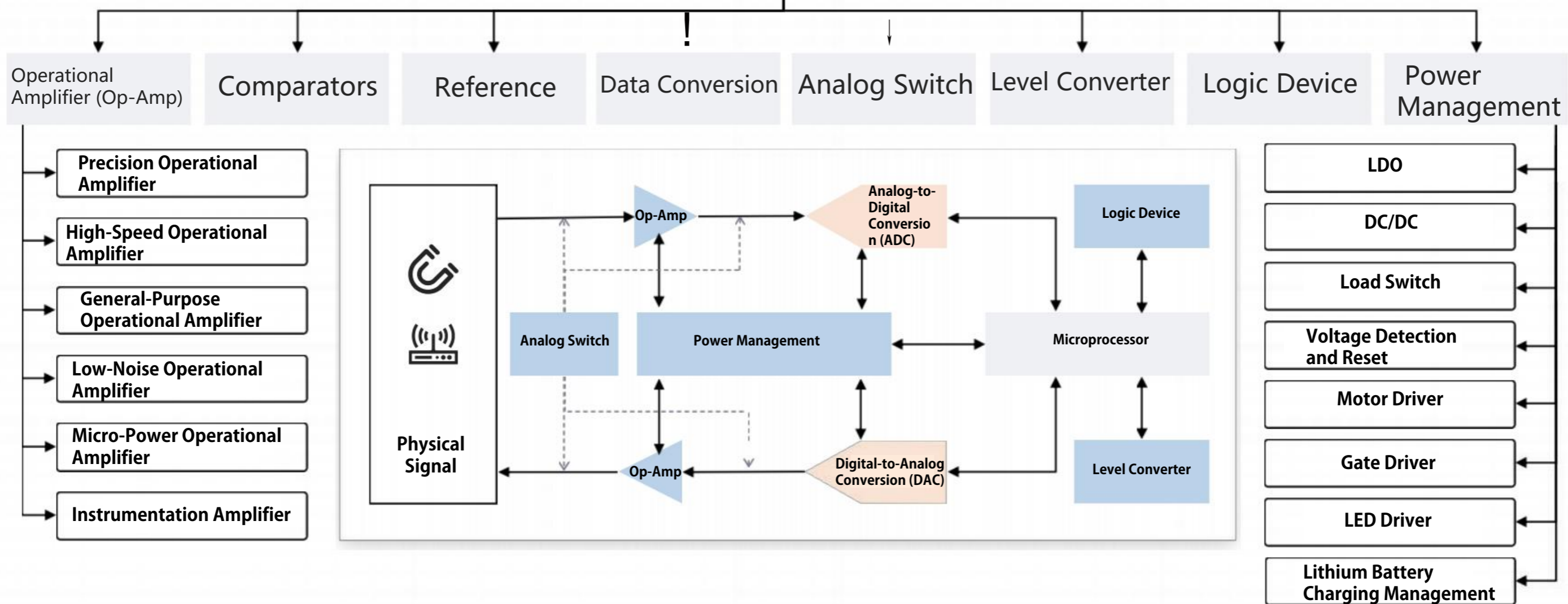

Zhi Xin Wei Product Line

Developed over 280 chip models across eight major categories: Safety, Main Control, Communication, Sensing, Radio Frequency Identification, Storage, Artificial Intelligence, and Analog. This covers the functional needs of chips across nearly all industrial sectors.

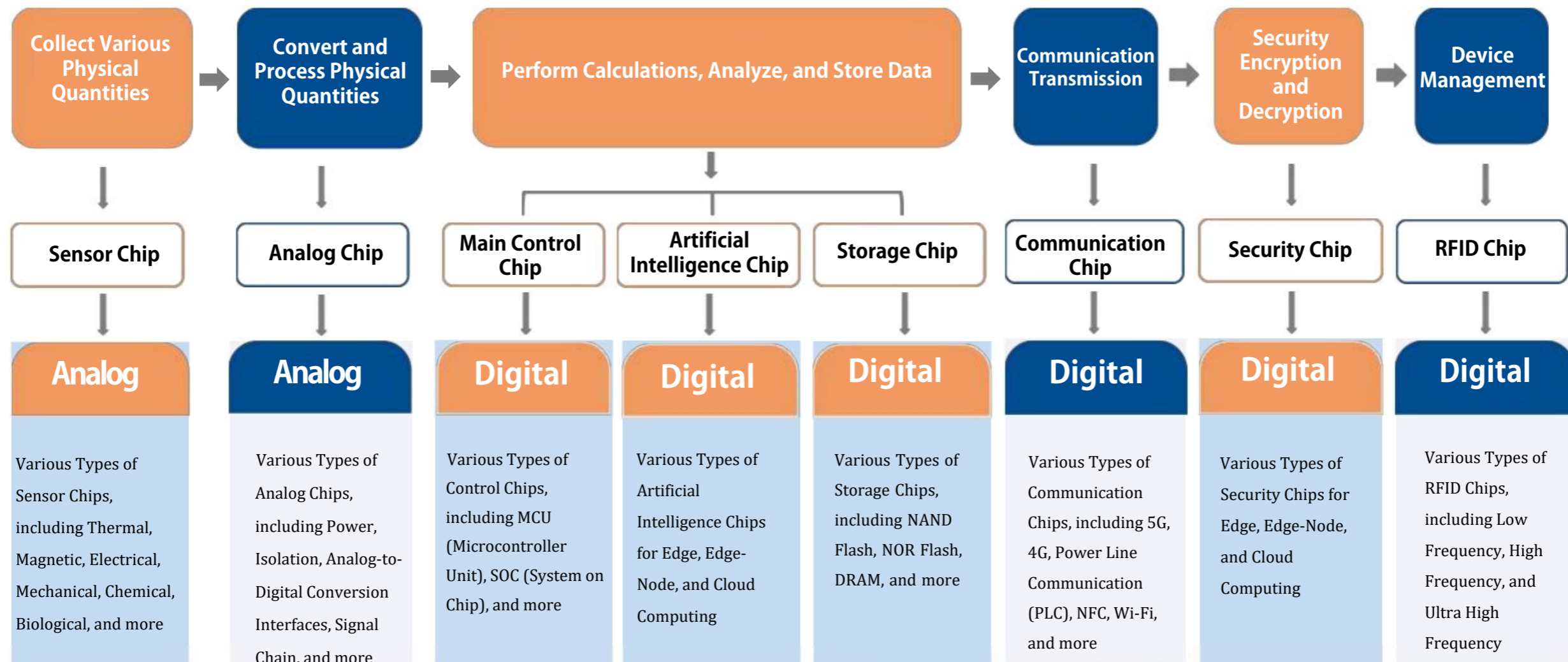



National Technology Product Line

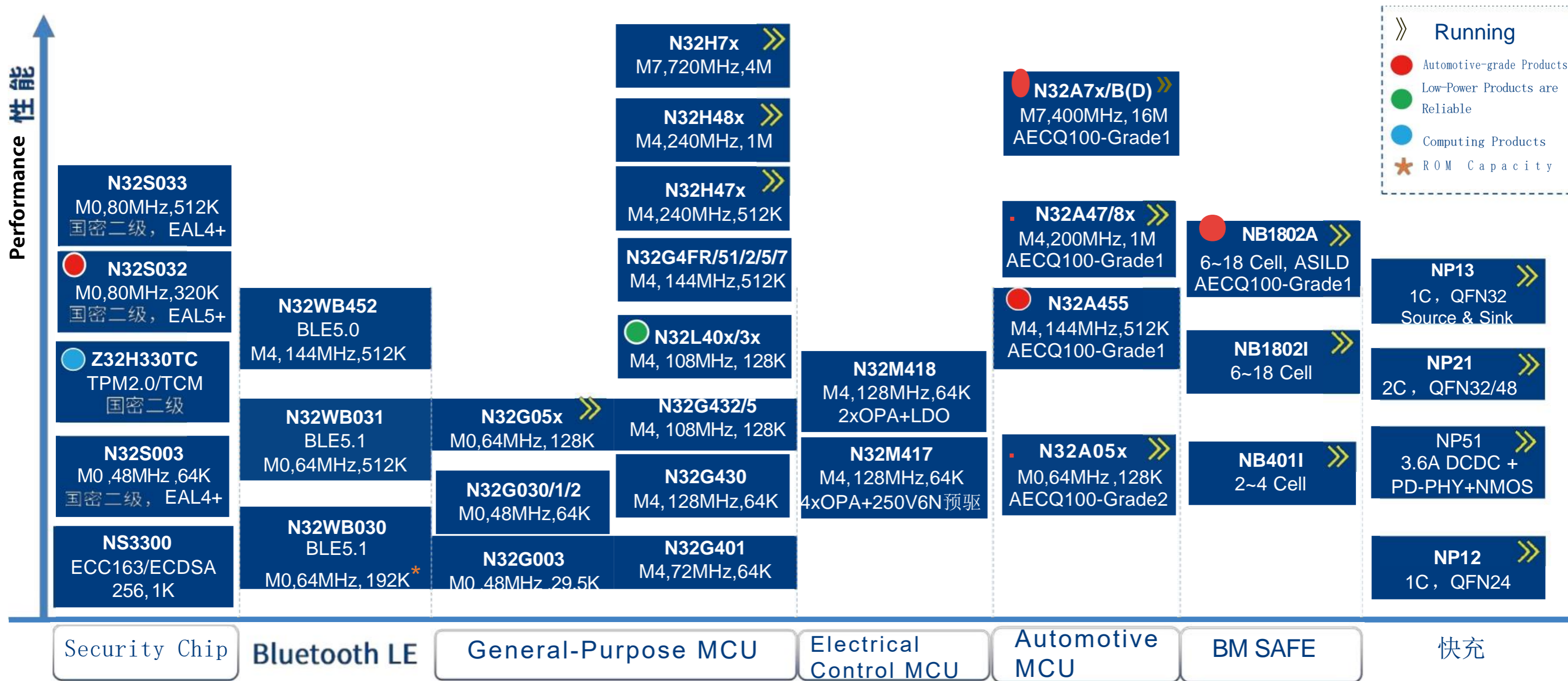

Diverse Product Range

Focusing on the "General-Purpose + Security" Market, innovating and developing technologies and products such as General-Purpose MCUs, Security Chips, Wireless RF, and Power Management.

